

# HOPE

HG53041E

## HOPE EXA EXCESS AIR GAS BURNER HANDLING MANUALS

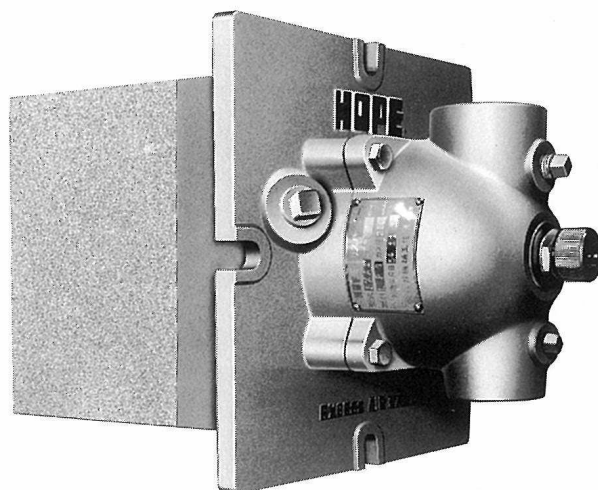

**YOKOI KIKAI KOSAKUSHO CO., LTD.**

Head Office:

2720-1, Oboraguchi, Nakashidami, Moriyama-ku

Nagoya 463, Japan

Tel: +81-52-736-0773 Fax: +81-52-736-0258

## TABLE OF CONTENTS

	P
1. Confirmation,Overview and Specifications of the Unit and Accessories	1
2. Safety Precautions	2 ~ 3
3. Notes for Mounting the Burner Flow Sheets	4
4. Operation Manual(Preparation,Ignition,Adjustment and Extinction)	5
5. Inspection and Maintenance(Disassembly,Cleaning and Reassembly)	6
6. Warning Plate Troubleshooting	7
7. Structural Drawing	8

Thank you very much for choosing HOPE EXA type Excess air gas burner.

To get maximum performance out of your new gas burner and to properly maintain and inspect the unit, please read through this manual carefully. Keep it handy for future reference. Please ensure that both construction company and end user will get this manual.

### Inspection after Purchase

Check the name plate and the following specification table to make sure that the product is per your order. Also check if it is free from any transportation damage.

### Overview

The EXA type excess air gas burner is a nozzle-mix type burner, which allows combustion of high excess air by adopting multi-pod air nozzle. The stable combustion makes it suitable for a variety of industrial furnaces such as heating furnace, drying furnace, heat treatment furnace, and hot-air producing furnace.

### SPECIFICATION

TYPE	CAPACITY kW	CONNECTION		MASS kg
		GAS	AIR	
EXA - 1	97	Rc 1	Rc 1 1/4	19
EXA - 2	166	Rc 1	Rc 1 1/2	19
EXA - 3	255	Rc 1	Rc 2	19
EXA - 4	453	Rc 2	Rc 3	39
EXA - 5	724	Rc 2	Rc 4	39
EXA - 6	1060	Rc 3	125A	80
EXA - 7	1530	Rc 3	150A	83

- Standard Pressure : GAS 2 ~ 10 kPa  
AIR 6 kPa

## Matters to be attended for safety

Before installing, trial- operating, maintaining or inspecting this burner, please learn the inside of this burner, information of safety and other matters to be attended by reading this instruction manual and all of attached documents.

The rank of the matters to be attended is classified to "Top danger" "Danger" and "Caution" in this instruction manual.



In case of wrong operating, it is predicted that serious dangerous situation will happen and the operator or other people.  
May die or may be seriously injured.



In case of wrong operating, it is predicted that dangerous situation will happen and operator or other people may die or may be seriously injured.

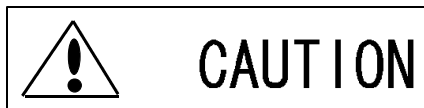

In case of wrong operating, it is predicted that dangerous situation will happen and the operator or other people will be injured or only material described.

NOTE, Even the matters classified to CAUTION have a possibility of causing serious results. Then, never fail to abide by matters described.

	Meaning of the mark	Sample
 COMPULSION	This is to tell that there is indication to instruct compulsorily your action. contents of the instruction must be described definitely nearby.	 never fuel to do
 PROHIBITION	This is to tell the prohibited action. Specifically prohibited action are described.	 TOUCH PROHIBITED
 CAUTION	This is to tell that there is a thing to be attended. The specifically attended thing is described nearby.	 CAUTION HIGH TEMPERATURE

**Read without foil**



Never fail to exhaust the air in the furnace (pr-purge) before igniting. Repeated ignitions may cause explosion due to the gas stagnated in the furnace. Please install safety devices like a flame supper visor.



**ELECTRIC SHOCK  
CAUTION**

Never fail to cut the electricity of transformer when you take off the ignition plug in order to i check the spark of it.

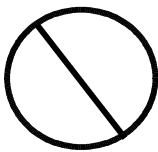

Never fail to take off the site hole when igniting or firinf the burner.  
※ flame in the furnace may blow out.



**TOUCHING  
PROHIBITED**

Never touch the mounting plate of the burner and fitting parts of the pilot burner. These area are high temperature when the burner is burning.

1. Do not use the attached gasket for sering this burner.
2. Put the replaced old gaskets pouch and thrae'away therm according to the waste disposal regulation or the waste cleaning regulation.  
Never burn up them.

## Mounting

- 1) Support the exterior surface of the burner tile, particularly the bottom face with fire block, castable refractories or other appropriate materials so that the burner tile will not fall down,
- 2) 'When mounting the burner to the furnace, secure it by filling the space between the mounting hole and the burner tile with the fire-resisting mortar.

## Piping

- 1) Clean the piping thoroughly so that any seal tape, bond, chip or other materials will not be left inside. Failure to do so may result in the malfunction of solenoid valve, governor, other valves and parts.
- 2) Attach piping support when connecting the pipes so that the burner will not be under unnecessary load.
- 3) The air orifice is built in to the HGS. Perform piping in such a way so that the straight pipe before the burner entrance will be at least 3 times longer than the pipe diameter. Attach pressure cocks to the air and gas pressure difference detection taps (4 areas).
- 4) When you choose the fan, pay attention to the non-combustion air capacity listed in the catalog.

EXA-TYPE  
EXCESS AIR GAS BURNER

(1) PRESSURE BALANCE VALVE METHOD

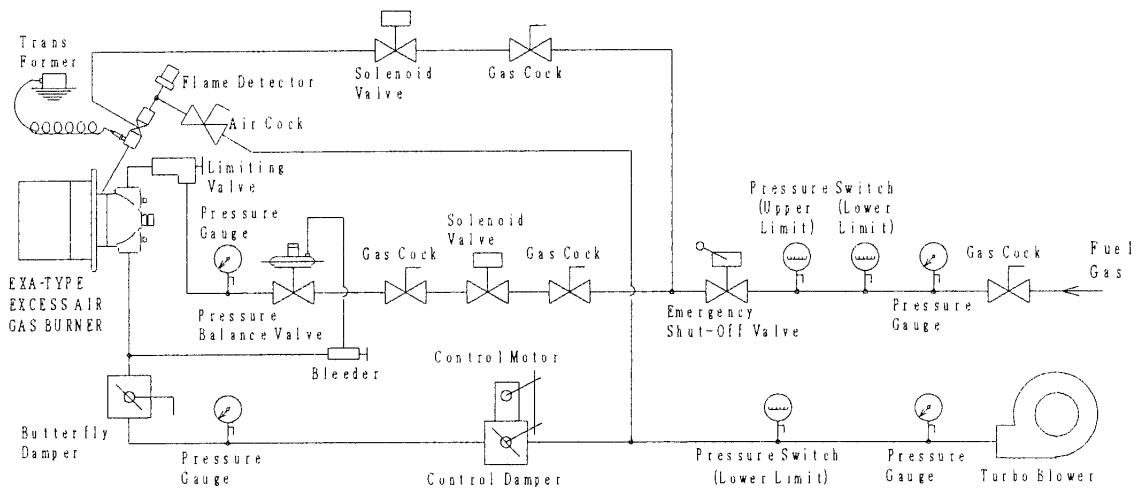

(2) INTERLOCKING METHOD

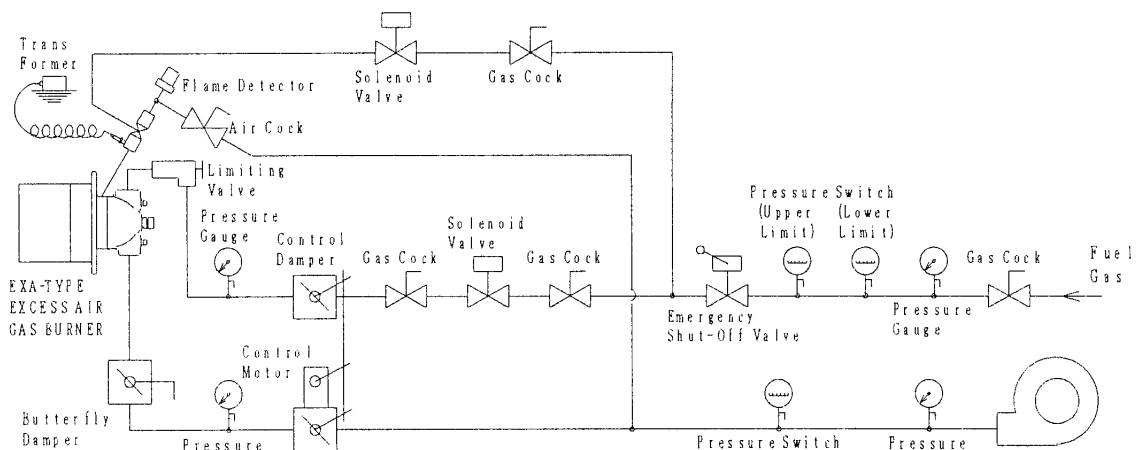

## OPERATION MANUAL

### Preparation

- 1) Make sure that all the gas cocks are closed.
- 2) Use air, nitrogen or other appropriate gas to check the leak inside the gas piping
- 3) Check if all the equipment for air and gas lines work properly..
- 4) Make sure that the gas is supplied as per specified pressure and that the gas inside the piping has been replaced.
- 5) Start the blower and check if the outlet pressure is per specifications.
- 6) Use the control damper to set the maximum combustion (6kPa) and the minimum combustion (0.1 ~ 0.5kPa).
- 7) Fully open the control damper and purge inside the furnace with air (You need to purge area that is approximately 3 times larger than the furnace capacity).
- 8) Set the control damper to the minimum combustion.

### Ignition

- 1) Make sure that the cock before the burner, solenoid valve and limiting valve are fully closed.
- 2) Ignite the pilot burner by pressing the ignition button. (Always use the pilot burner. Use of torch or igniter rod is dangerous. Also, check if the ignition was made securely.)
- 3) Fully open the cock before the burner and the solenoid valve. Slowly open the limiting valve and check if the main burner was ignited securely.

### Adjustment

- 1) Measure the pressure difference of air orifice and acquire the air capacity from the table.
- 2) Calculate the required gas capacity and acquire the pressure difference of orifice that suits the flow. Use the limiting valve to set the pressure difference. At this time, make sure to convert the specific gravity of the atmosphere.
- 3) When using the equalizing valve control, slowly open the control damper to the maximum combustion as you check the combustion status. Check the flow rates.
- 4) Use the flame detector to check the current value.
- 5) When the air ratio setting is completed, set the control damper to the minimum combustion again. Joint the control motor and the control damper so that the necessary turndown will be obtained.

### Notes

- 1) The pressure inside the burner tile becomes high during the combustion, and removing the sight hole may expose you to the flame. Pay special attention to the looseness of the sight hole or glass daniage.
- 2) There are 3 types of orifices available depending on the type of gas. A plate that indicates the orifice size is attached to the flange bolt where the gas orifice is fitted. Use the following table to confirm the orifice size.
- 3) An orifice built in to the burner is intended to serve as adjustment guide. If you need more accurate value, we recommend to install MO type metering orifice at some midpoint in the piping.

### Extinction

Fully close the cock before the burner and the solenoid valve, and check if the flame has been extinguished.

To protect the nozzle, wait until the furnace temperature falls down below 500 °C before stopping the combustion blower.

### **Inspection (Inspection of Nozzle and Burner Tile)**

\* Inspection should be performed when the furnace has been cooled. Always wear protective gloves and other safety devices.

1 Make sure that all the powers such as of the combustion blower have been turned off.

2 Check if all the cocks have been closed.

3 Loosen the union and other sections of the gas piping.

4 Loosen the hex bolt that secures the Burner Plate ② and the burner body ①.

(Make sure that the burner body has been cooled before following this step.)

5 Hold the burner body ① securely and remove the Burner Plate ②. At this time, handle it with caution so that the Nozzle Plate ④ will not fall down.

(The burner body ① and the Nozzle Plate ④ are not secured to each other;

removing the burner body ① releases the Nozzle Plate ④ at the same time. Also, the panel may be very hot.)

Handle them with extra caution as hot air in the furnace may blow out from between the Burner Plate ② and the burnerbody ①.

6 When the burner body ① and the Nozzle Plate ④ have been removed from the Burner Plate ②,

check for any deposits of foreign particles around the air nozzle ⑤

and the gas pipe ⑥. Check for any loose parts.

Then check the burner tile:

7 Clean it free of any foreign particles. Contact us if the burner tile is damaged. It may adversely affect the combustion.

8 Reassemble the parts when you make sure that they are not defective (Do not forget to tighten any parts or piping).

\* Check the burner and accessories as adequate, depending on the conditions of use.



## ※ WARNING PLATE

Please check whether the warning plate shown below is removed from the burner body after installation looks finished. If the warning plate was lost , please let our sales department know it.

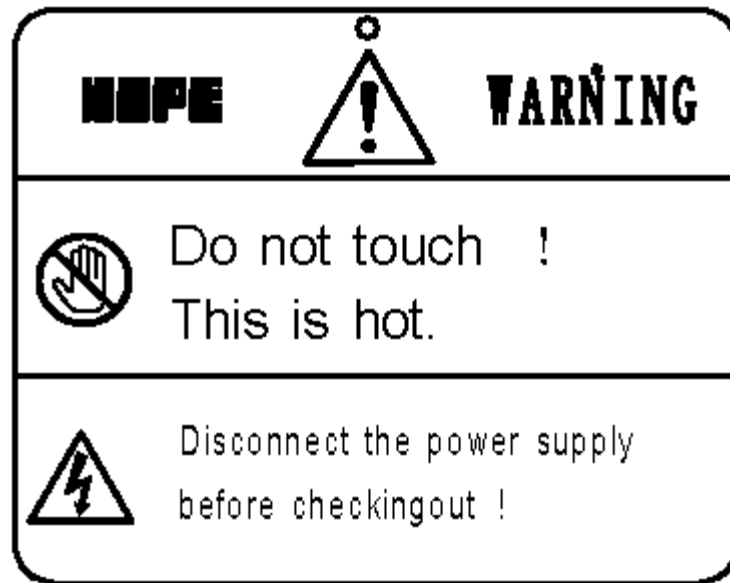

## Troubleshooting

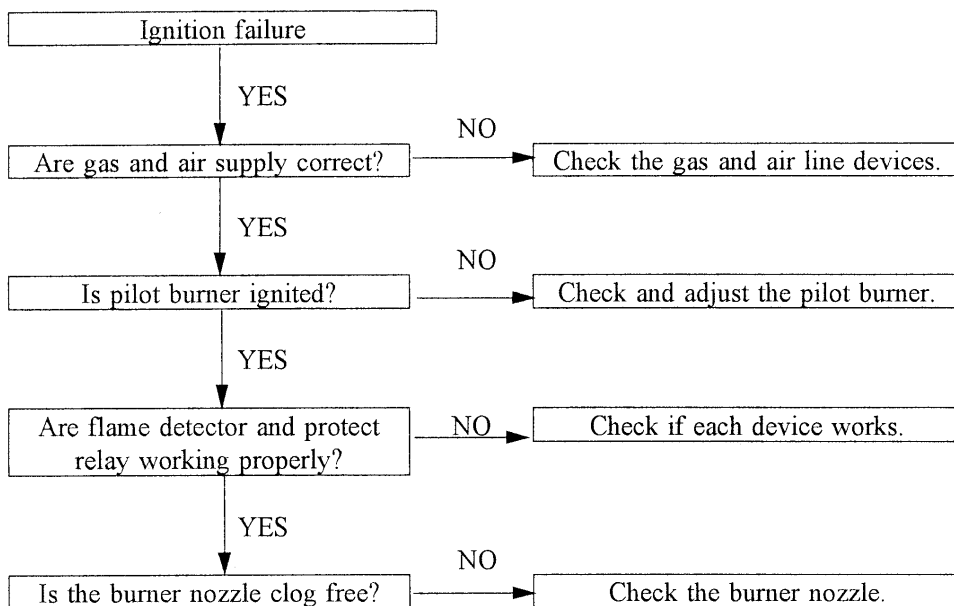

\* For details on how to inspect the burner and peripheral devices, see the user s in annual of each unit.

\* Contact our Sales Department for any questions:

Tel: +81-52-736-0773

Fax: +81-52-736-0258

# Structual Drawing

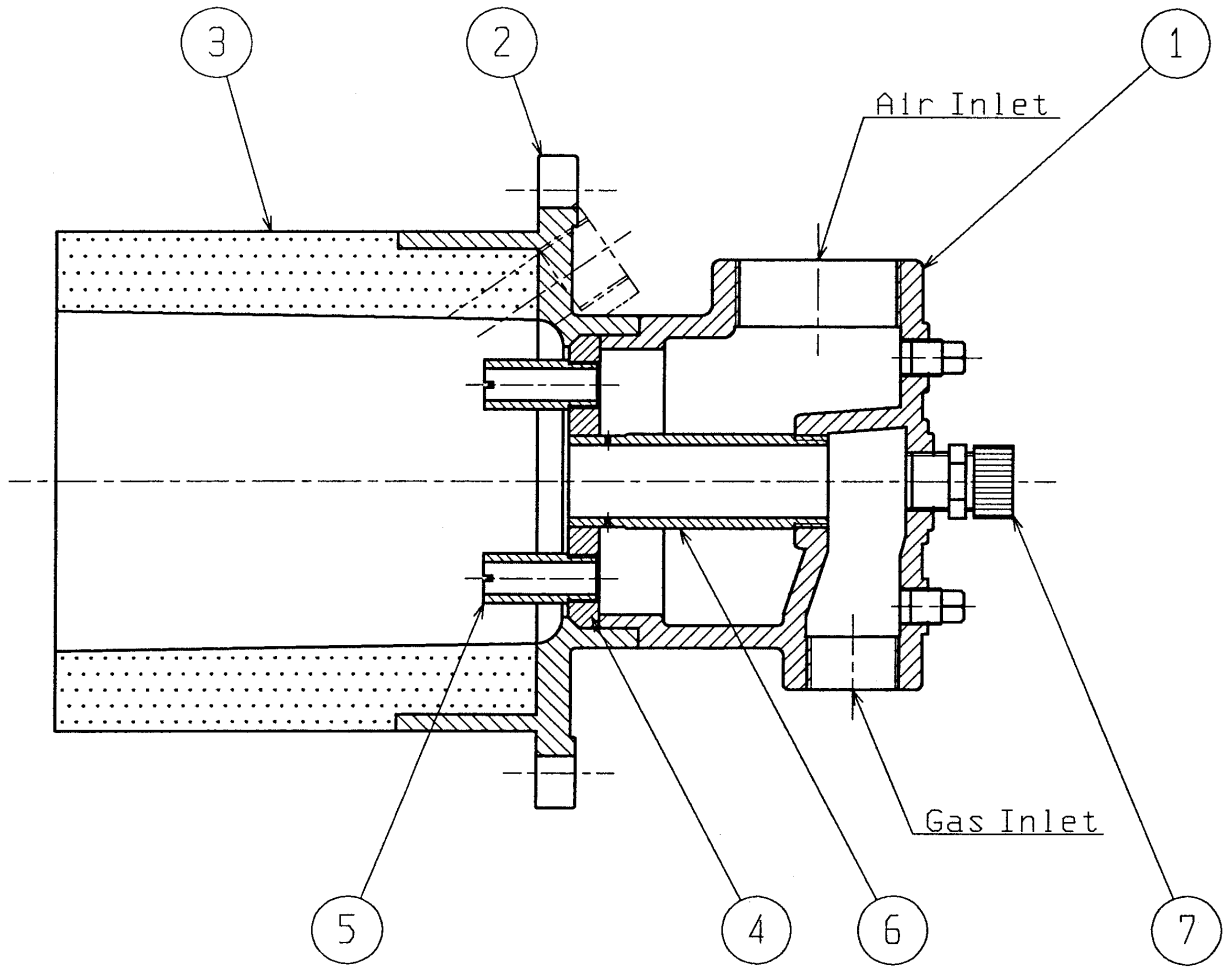

No.	PARTICULARS	QUAN.
1	Burner Body	1
2	Burner Plate	1
3	Burner Tile	1
4	Nozzle Plate	1
5	Air Nozzle	8
6	Gas Pipe	1
7	Sight Hole	1