



写真はセラミック燃焼筒仕様です (MJ-2C)

本機は、従来のキャスタータイプを無くし、小型・軽量化になっており燃焼ガス流速が低速から高速まで機種対応が可能で高温炉用には、特殊耐熱燃焼筒を採用しております。ダイレクト点火方式を採用しておりますので設備費にコストダウンがはかれます。

金属加熱、窯業焼成炉、溶解炉、メッキ炉、取鍋加熱等多用途に適しています。

This is a small-sized, light-weighted burner dispensed with conventional caster style. It can be applied to a wide variety of gas flow rates from low to high. For high-temperature furnace applications, a special heat-resistant heat chamber type has been adopted. The employed direct ignition method reduces the equipment cost. This burner is suitably applicable to metal heating furnaces, ceramics firing furnaces, melting furnaces, plating furnaces, ladle heating and many other uses.

- 燃 料 Fuel : 各種燃料ガス Fuel Gases
- 基 準 圧 Standard Pressure : Gas 2 ~ 10kPa · Air 6kPa
- 炎監視方式 Flame Safeguard System : 紫外線光電管方式 UV Phototube

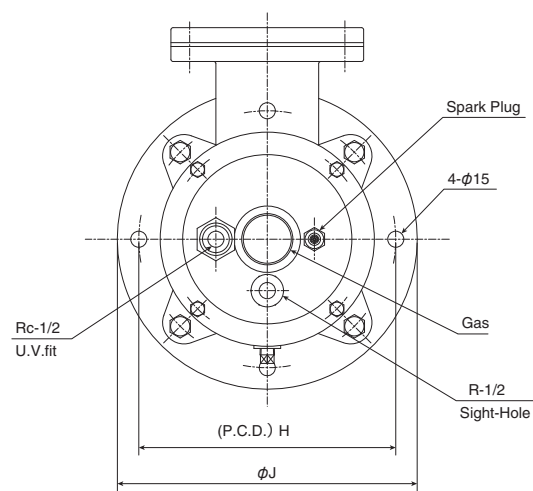
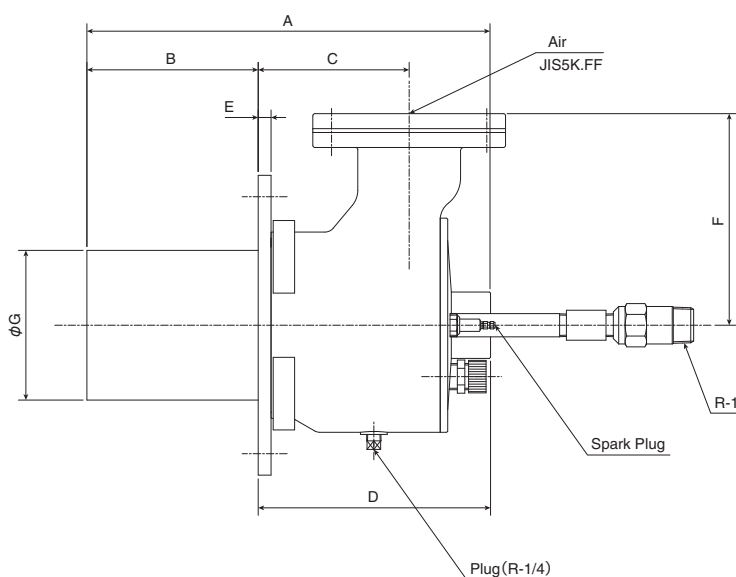

寸 法 / DIMENSION

型式 Type	燃焼容量 Cap. kW (x10 ³ kcal/h)	空気流量 Air Flow Rate (m ³ /h (nor.))	接続口径 Connection		A	B	C	D	E	F	G	H	J	質量 Mass (kg)
			Air (JIS5K)	Gas (Rc)										
MJ-1	58 (50)	60	40 A	3/4	304	120	110	184	12 (17)	156	102	160	200	15
MJ-2	116 (100)	120			(309)		(115)	(189)						
MJ-3	174 (150)	180	65 A	1	314	140	101	174	12	169	114	200	240	17
MJ-4	233 (200)	240												
MJ-5	350 (300)	360	80 A	1 1/2	377	160	141	217	12	199	140	240	280	27
MJ-6	460 (400)	480												

※()はセラミック筒の場合 ※ ()…Ceramic TYPE.

フレイムパターン / FLAME PATTERN

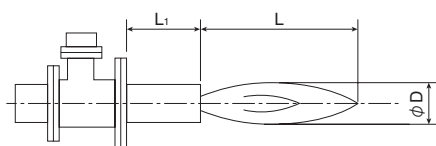

● 運転条件 Condition / 大気中 In The Air	
燃焼空気圧力 Air Pressure	6kPa
燃 料 Fuel	LPG
空気比 Excess Air Ratio	1.1

Type	φ D	L	L ₁
MJ-1	100	500	120
MJ-2	100	600	120
MJ-3	150	650	140
MJ-4	150	700	140
MJ-5	200	700	160
MJ-6	250	800	160