

HOPE

H002084E

HOPE YLP PROPORTIONING OIL BURNER HANDRING MANUALS

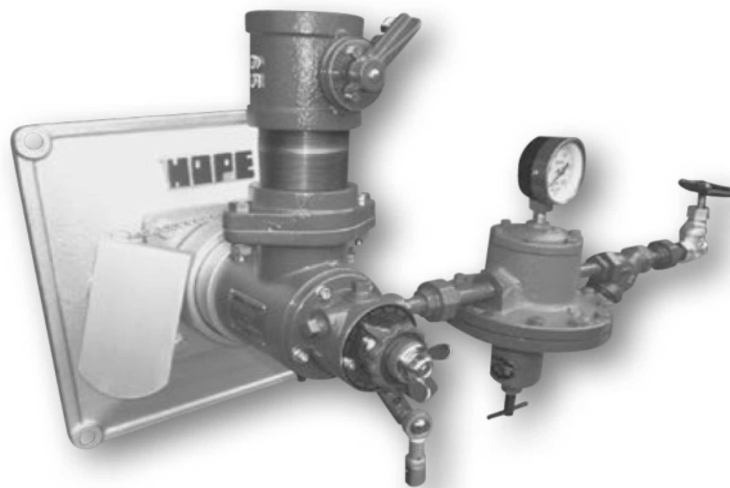

YOKOI KIKAI KOSAKUSHO CO., LTD.

Head Office:

2720-1, Oboraguchi, Nakashidami, Moriyama-ku
Nagoya 463, Japan

Tel: +81-52-736-0773 Fax: +81-52-736-0258

TABLE OF CONTENTS

	page
Inspection of Product and Accessories. Outline.	1
Specifications. Installation.	2
Matters to be attended for safety.	3
Read without fail.	4
Air pipng. Oil pipng(1). Flow sheat.	5
Oil pipng (2). (3). (4). (5). (6)	6
Operation (Preparation for operation. Firing. Adjustment and Fire extinction)	7
Automatic control.	8
Disassembly.	9
Cleaning. assembly. Structure of accessories.	10
Maintenance and inspection. Warning plate.	11
Troubleshooting.	12
Structure drawing. About structure.	13
Technical data (Oil flow quantity characteristic)	14
Technical data (Air flow quantity characteristic)	15
Technical data (Air pipng. Pressure loss)	16

Thank you for your selection of HOPE PROPORTIONING OIL BURNER Type YLP. Please carefully read this instruction manual in order for you to be fully satisfied with the performance of this burner and to secure the safety in operation, maintenance and inspection. Also, please be sure to deliver this instruction manual to the end user, as well as to the constructor.

■ Outline

HOPE YLP TYPE PROPORTIONING OIL BURNER can adjust the air quantity and the oil quantity proportionally by operating only the air control handle. This burner can easily provide stable combustion, and therefore, is widely used for various industrial furnaces and ceramic furnaces.

This burner is featured as follows:

1. It can proportionally adjust the oil quantity and the air quantity by operating only the air control handle.
2. When the automatic control unit is installed, the in-furnace temperature can be controlled easily.
3. As it can provide complete combustion with low excess air, it can save energy.
4. Its turndown ratio is so large (1:5) that it can provide stable combustion.
5. As it is of low-pressure air atomizing type, it does not require any atomization piping.

■ Inspection of product and accessories

Check to confirm whether or not the product is exactly in accordance with your order by referring to the nameplate and the specification table given below. Also check for damage and other irregularities caused by and during transportation.

1. Difference in burner type by fuel type . . . “L” or “H” indicated both on the model column of the nameplate and on the back side of the oil control spindle. Here, “L” means kerosene type, and “H” means heavy oil type.
2. Confirmation of the standard accessories . . . When you placed an order for the burner as a set, confirm that you have received all the following accessories:

Standard accessories ① Butterfly Damper ② Reducing Valve ③ Oil Strainer
 ④ Stop Valve ⑤ Pressure Gauge ⑥ Burner Tile
 ⑦ Mounting Plate ⑧ Burner Support ⑨ Shutter

- ※ For the name of each part, refer to the installation drawing.
- ※ The reducing valve, the oil strainer and the stop valve are shipped out as a set unless otherwise specified.
- ※ For the burner tile, YLP-1 through 4 are two-fraction tiles and YLP-5 through 8 are four-fraction tiles.

Assembly figure

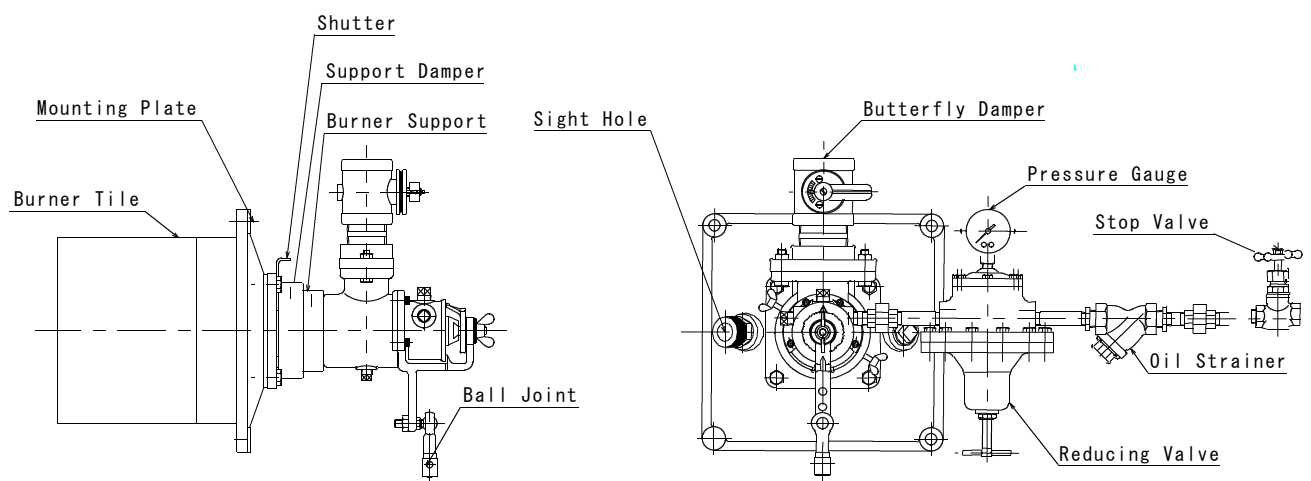

■ Specification

Type	Capacity (kW)	Connection		Mass (kg)
		Oil (Rc)	Air	
YLP-1	65	3/8	Rc 1 · 1/2	50
YLP-2	108	3/8	Rc 2	51
YLP-3	194	3/8	Rc 2 · 1/2	63
YLP-4	367	1/2	Rc 3	122
YLP-5	541	1/2	Rc 4	176
YLP-6	649	1/2	Rc 4	176
YLP-7	1081	1/2	125A	363
YLP-8	1622	1/2	150A	469

■ Installation

1. In installing the burner to the furnace body, fill up the clearance between the burner mount of the furnace and the burner tiles with refractory mortar and fix the burner to the furnace.
2. Fix the outside of the burner tile, particularly its lower surface, with firebrick, castable refractory or the like to protect the burner tile from being dropped. Also, arch the top portion so that the burner tile can be replaced easily.

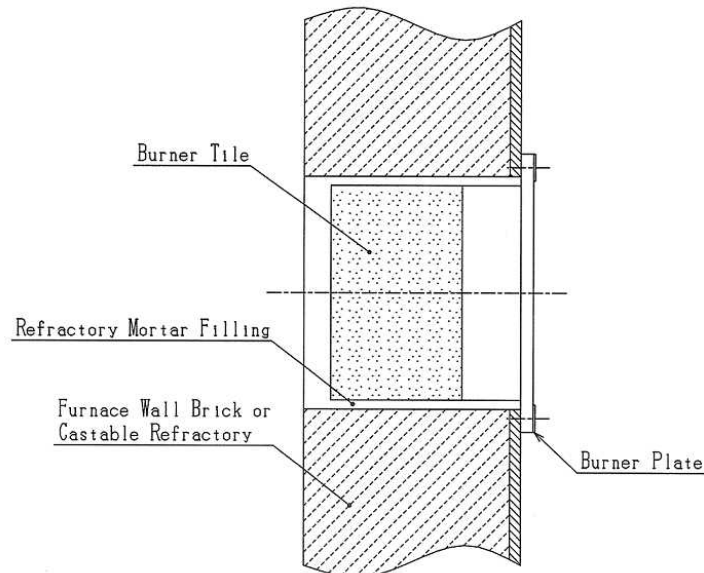

3. Precisely align the burner body with the burner tile along the center line and align the burner plate with the burner tile along the sight hole.
4. In connecting the pipes, provide pipe support in proper positions to prevent the application of any excess force. Insert the burner body deep into the burner support, and fix it with the set bolt.
5. To install the pilot burner, screw it in the sight hole of the burner plate.

■ Matters to be attended for safety

Before installing, trial-operating, maintaining or inspecting this burner, please learn the inside of this burner, information of safety and other matters to be attended by reading this instruction manual and all of attached documents.

The rank of the matters to be attended is classified to "Top danger" "Danger" and "Caution" in this instruction manual.



In case of wrong operating, it is predicted that serious dangerous situation will happen and the operator or other people may die or may be seriously injured.





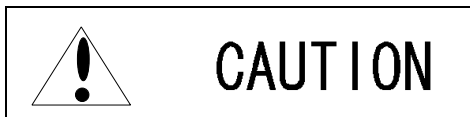



In case of wrong operating, it is predicted that dangerous situation will happen and the operator or other people may die or may be seriously injured.

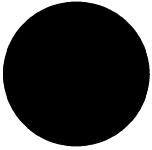

In case of wrong operating, it is predicted that dangerous situation will happen and the operator or other people will be injured or only material described.

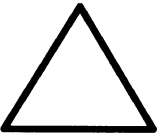
NOTE, Even the matters classified to CAUTION have a possibility of causing serious results. Then, never fail to abide by matters described.

	Meaning of the mark	Sample
 COMPULSION	This is to tell that there is indication to instruct compulsorily your action. Contents of the instruction must be described definitely nearby.	 NEVER FAIL TO DO
 PROHIBITED	This is to tell the prohibited action. Specifically prohibited action are described.	 TOUCH PROHIBITED
 CAUTION	This is to tell that there is a thing to be attended. The specifically attended thing is described nearby.	 CAUTION HIGH TEMPERATURE

■ Read without fail



Never fail to exhaust the air in the furnace (pr-purge) before igniting. Repeated ignitions may cause explosion due to the gas stagnated in the furnace. Please install safety devices like a flame supper visor.

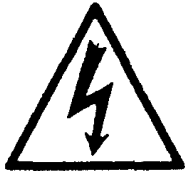

Never fail to cut the electricity of transformer when you take off the ignition plug in order to check the spark of it.



Never fail to take off the site hole when igniting or firinf the burner.
※flame in the furnace may blow out.



**TOUCHING
PROHIBITED**

Never touch the mounting plate of the burner and fitting parts of the pilot burner. These area are high temperature when the burner is burning.

■ Air Piping

1. Minimize pressure loss due to piping resistance. For the piping up to the burner, secure the connection diameter equal to or larger than the specified connection diameter. Set the air rate within the main air piping to around 10m/sec.
2. Employ a blower that has a small pressure variation. If pressure variation is too large for air quantity variation, proportional combustion is difficult.
(In this case, HOPE SSTB TYPE SILENT BLOWER is recommendable.)
3. Install the air inlet of the burner upward or sideward. If it is installed downward, oil may flow in the air piping.
4. In a dusty place, install the blower in a position where the blower can feed fresh air throughout the place.

■ Oil Piping

1. If the oil piping is not complete, the capacity of the burner cannot be exerted fully, and even combustion may be difficult. Particularly in a case where heavy oil is used, lay pipes by referring to the flow sheet given below.

Flow Sheet

(1)

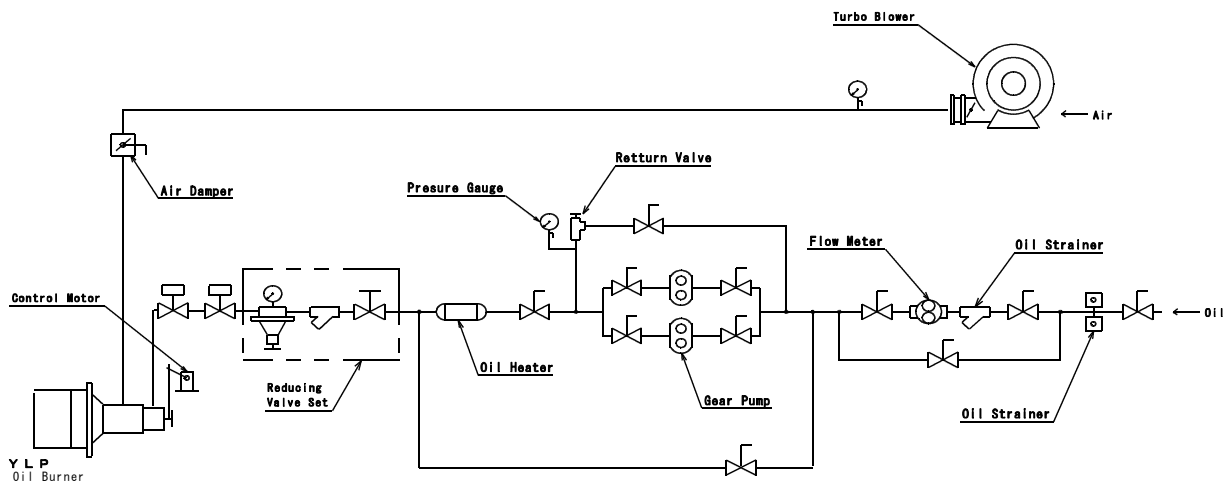

(2)

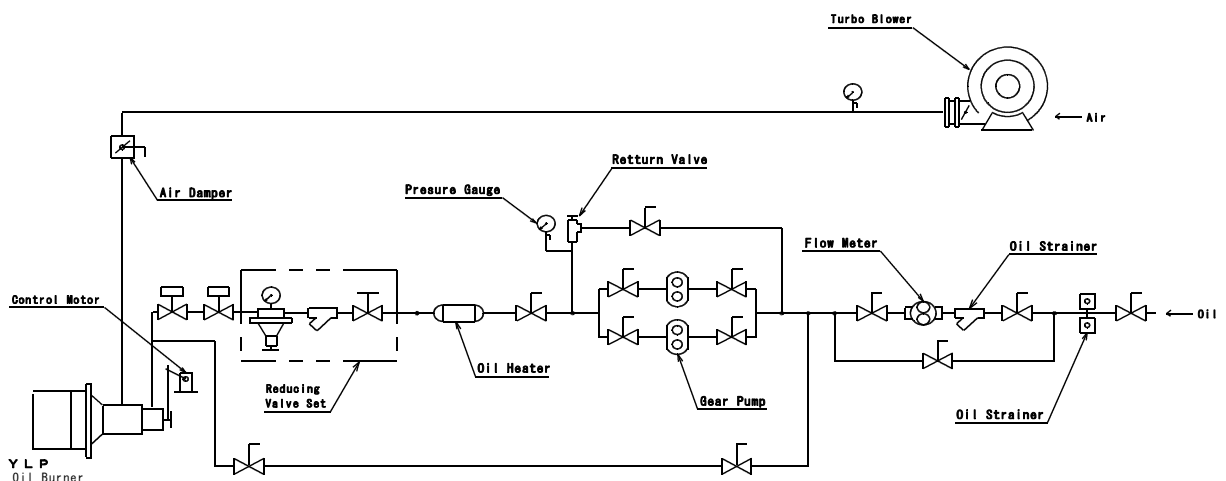

- Heat heavy oil to the specified temperature.
Maintain the heavy oil temperature at the burner inlet to the temperature given below.

Kerosine : Normal temperature
 Light oil : Normal temperature
 A heavy oil : 50 °C
 B heavy oil : 80 °C
 C heavy oil : 100 °C

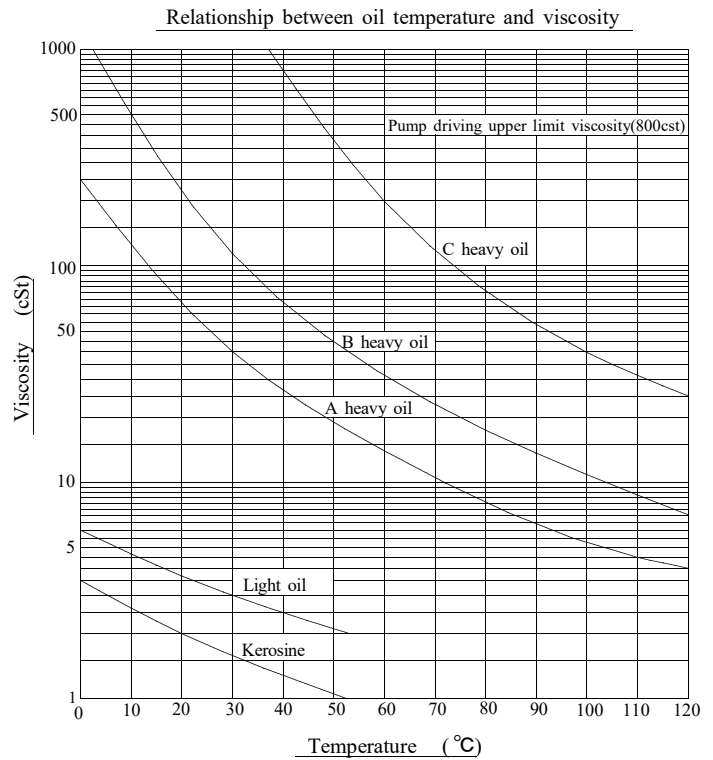

- Particularly, heavy oil remains within the piping or the burner after the burner stops and may be coagulated or carbonized by heat. Therefore, after the burner stops, drain the remaining oil completely. One of the draining methods is to purge the piping and the burner of the remaining oil as shown in Fig. 1.

Fig.1

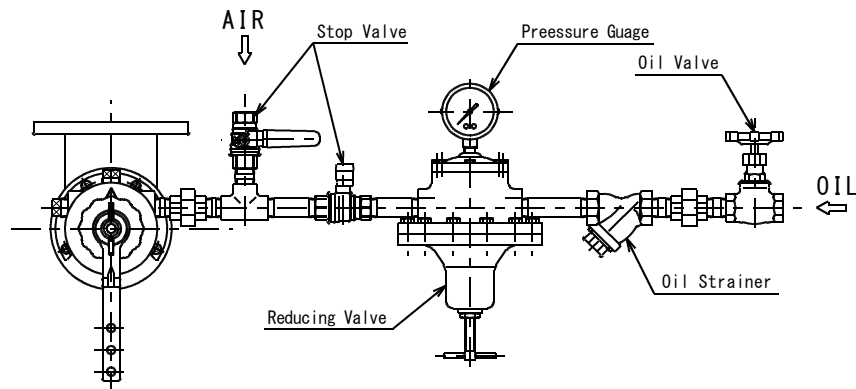

Note: To protect the diaphragm of the reducing valve from being broken, close the stop valve on the secondary side of the reducing valve. (Withstand pressure: 0.2MPa)

- If the oil level of the service tank is lower than the burner position, install a check valve to prevent the back flow of oil. When an oil heater is used, be sure to return the oil into the service tank.
- There are 3 oil inlets leading to the burner. The piping may be connected to any of these inlets.
- When installing the reducing valve set (i.e., reducing valve, oil strainer, stop valve), be careful not to admit foreign objects into a gap between the oil strainer and the burner. Particularly note with care that seal tape chips, piping chips and the like may clog the gap.

■ Operation

1. Preparation for operation

- ① Fully open the air butterfly damper. Confirm that the oil control handle is in the scale “S” position, and fully open the stop valve at the oil inlet. (Loosen the fixed butterfly nut behind the burner beforehand.)
- ② Open all the stop valves of the oil piping, and fully open the return valve of the oil feed pump.
- ③ Start the oil heater.
- ④ Start the oil feed pump to drain the air completely from the piping. Confirm that the pressure gauge needle is stabilized, and adjust the return valve to set the oil pressure to 50kPa.
- ⑤ Adjust the reducing valve to the specified pressure. (Fine-adjust it after the burner is ignited.)
- ⑥ Pull out the protective shutter from the burner.
- ⑦ Start the blower, and fully open the air control handle. (Be sure that the oil control handle is in the scale “S” position.) Remove the plug from the burner body, and confirm the air pressure. → The standard pressure is 6kPa.
- ⑧ Fully open the flue damper to release unburned gas from the furnace.
- ⑨ Confirm that the oil temperature has risen to the specified temperature at the burner inlet.

2. Ignition

- ① Adjust the air control handle to the scale 1 to 2.
- ② When the oil control handle is opened to the scale 2 to 3, the burner ignites.
- ③ Adjust the secondary pressure of the reducing valve to the specified pressure.
※ Normally, use the pilot burner for ignition.

3. How to adjust

- ① To proportionally combust air and oil, fasten the fixed butterfly nut to adjust the air scale and the oil scale to be the same.
- ② To combust air and oil together with the secondary air, adjust the support damper. At this time, the relation between the air scale and the oil scale has to be changed and the oil pressure has to be adjusted as well according to the secondary air quantity. Particularly, if the air is forcedly supplied, the maximum and minimum combustion capacities exceed the catalog values.
- ③ Set the oil pressure to the following standard set value:
 - a) YLP-L type with burner air pressure 6kPa and kerosene and light oil at normal-temperature viscosity
... 50kPa(only YLP-6L ... 70kPa)
 - b) YLP-H type with burner air pressure 6kPa and heavy oil viscosity 20cst
... 50kPa(only YLP-6L ... 70kPa)
 - c) YLP-L and YLP-H types with burner air pressure higher than 6kPa ... Raise oil pressure.
YLP-L and YLP-H types with burner air pressure lower than 6kPa ... Lower oil pressure.
 - d) YLP-H type with heavy oil viscosity higher than 20cst ... Raise oil pressure.
YLP-H type with heavy oil viscosity lower than 20cst ... Lower oil pressure.

4. Extinguishing

- ① Close the stop valve at the oil inlet, quench the burner, and return the oil control handle to the scale “S”
- ② Stop the oil heater, the oil transfer pump and the blower. (To protect the burner nozzle from radiation heat, continue the operation of the blower for a certain time after quenching the burner.)
- ③ Insert the protective shutter into the opening portion of the burner support.
- ④ Close the stop valve at the exit of the service tank.

5. Precaution

- ① As backfire may occur when the burner ignites, it is dangerous to bend over the burner.
- ② If the burner fails to ignite in 5 to 10 sec after oil is fed, return the oil control handle to the scale “S.”
After purging, redo the igniting operation.

■ Automatic Control

1. Outline

HOPE YLP TYPE PROPORTIONING OIL BURNER can proportionally control the air quantity and the oil quantity simultaneously only through the operation of the air control handle and the oil control handle, respectively. Therefore, automatic control can be performed easily by using an electric motor or the like.

2. Operating direction and angle of the air control handle

- ① The air control handle “closes” when it is turned clockwise and “opens” when it is turned counterclockwise as shown in Fig. 2.
- ② The operating angle of the air control handle is 90° . Therefore, when an automatic controller is connected, arrange the operation of the air control handle to be within 90° .

3. Relation between length of the air control handle and torque and stroke

Table 1 shows the power required for the operation of the air control handle. The numeric values in the table represent the factory default settings. In practical use, the handle moves heavily due to connection method, temperature and other conditions. Therefore, quadruple the equipment capacity shown in Table 1.

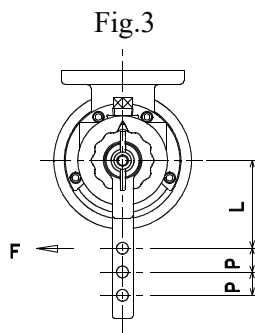
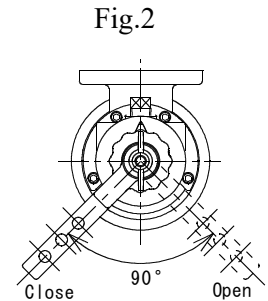

Table.1

Type	Power N	Handle Length mm	Pitch mm	Torque N · m
YLP-1	19.6	75	20	1.47
YLP-2	19.6	75	20	1.47
YLP-3	19.6	75	20	1.47
YLP-4	29.4	115	25	3.88
YLP-5	29.4	115	25	3.88
YLP-6	29.4	115	25	3.88
YLP-7	39.2	197	35	7.72
YLP-8	39.2	197	35	7.72

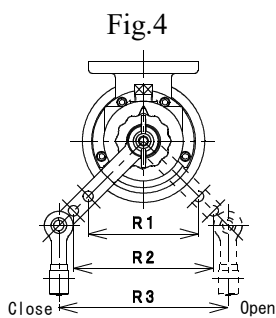

Table.2

	R1	R2	R3
YLP-1.2.3	106	134	162
YLP-4.5.6	162	198	233
YLP-7.8	278	328	377

※ Table 2 shows the numeric values when the air control handle is operated by 90°

4. Universal joint

It is a standard size of a universal joint.
One piece is attached to one burner.

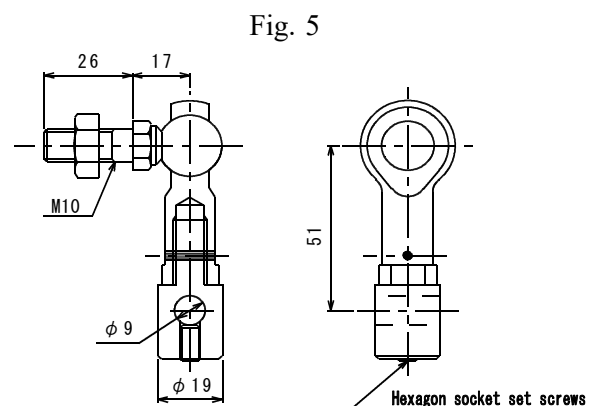

■ Disassembly

- a) Disassemble the reducing valve and the oil strainer at the union joint.
 - b) Loosen the hexagon socket setscrew from the burner support, remove the fixing bolt of the flange ⑩ and remove the burner.
 - c) Remove the hexagon socket head cap screw from the oil valve body ⑪, and take out the oil regulator and the air regulator (carrier).
 - d) Remove the guide screw ⑤, and disassemble the atomizer ② and the lead pipe ④.
 - e) Remove the operating bush ⑧ and the air control handle ⑨, and disassemble the oil nozzle ① from the oil valve body ⑪.
 - f) Remove the fixed butterfly nut ⑱, the fixed washer ⑲ and the inner-bladed washer ⑲, and disassemble the proportioning interlock ⑲.
 - g) Loosen the seal holder ⑮ by turning it counterclockwise, and disassemble a set of oil control spindle of ⑬ through ⑰.
 - h) Remove the taper pin ⑳, and disassemble the oil control handle ⑰.
 - i) Remove the seal holder ⑮, and take out the oil control spindle ⑭ together with the spindle holder spring ⑬.
- ※ Normally, it is not necessary to disassemble the operating bush ⑧ and the air control handle ⑨.

Fig. 6

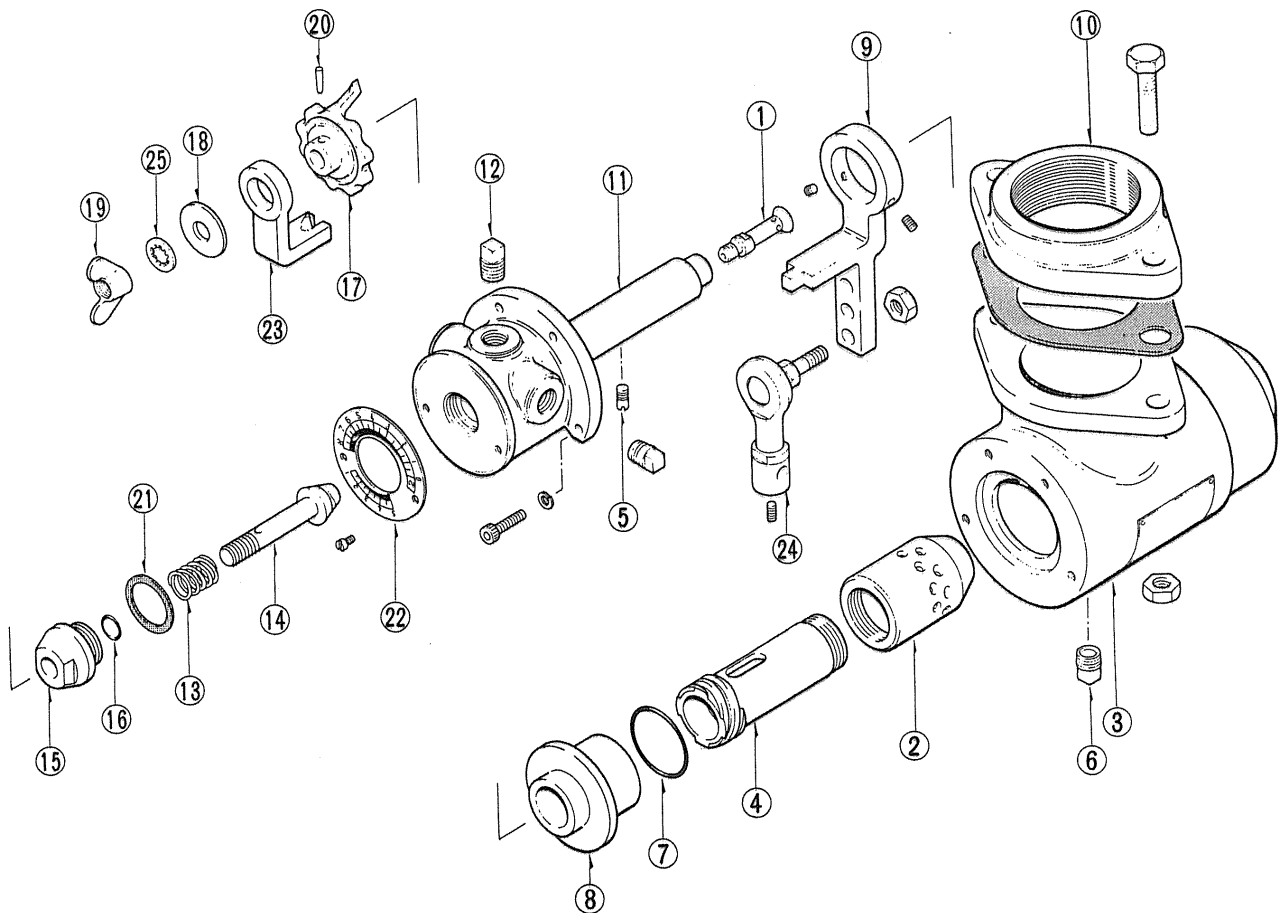

■ Cleaning. Assembly

- a) Clear the sliding portion between the oil control spindle and the oil valve body of foreign objects to protect the portion from flaw.
- b) Clear the burner of carbon and others.
- c) Apply sealing agent to the threaded portion of the oil nozzle and the oil valve body, and fasten them completely.
- d) Be careful not to damage the oil seal.
- e) A match mark is stamped on the operating bush and the lead pipe. Be sure to match the match mark before reassembling them.

■ Structure of accessories

1.Reducing valve (Fig.7)

- a) The reducing valve is designed to maintain the pressure of oil supply to the burner constant. To adjust the oil pressure, loosen the lock nut, and turn the oil pressure adjusting screw.
- b) If foreign objects invade, remove the top cover and clean the inside.
- c) Set the inlet pressure to 0.3MPa or less.

2.Oil strainer (Fig.8)

- a) You exclude the lower part chief regularly, and please clean the net part in air dusters

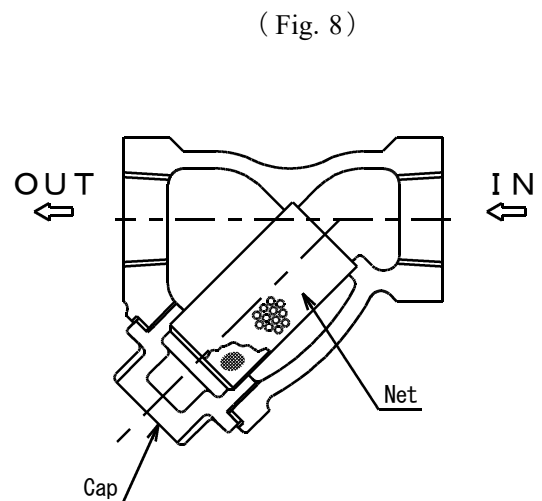
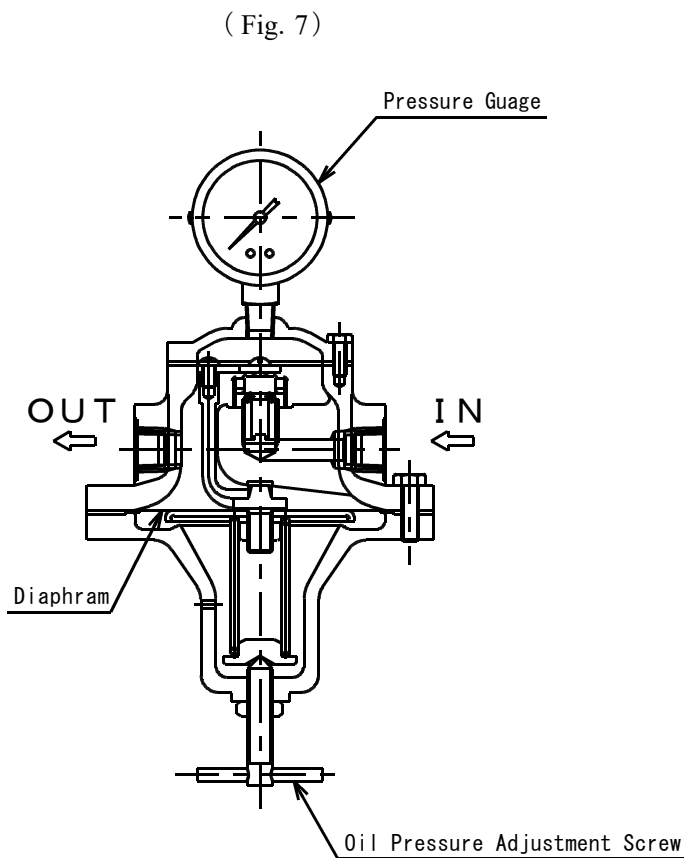

■ Maintenance and inspection

- 1.Clean the burner body and its accessories according to the fuel type and operation frequency.
- 2.If the atomizer of the burner body, the oil nozzle and the burner tile are contaminated with carbon and dirt and dust, combustion effect is degraded. Clean them periodically.
- 3.The air control handle may become heavy in operation due to the adherence of dirt and dust to the inside of the burner body and radiation heat. Clean the inside of the burner body periodically. Particularly, clean and apply heat-resistant grease to the contact surfaces among the operation bush, the lead pipe and the oil valve body. The guide groove of the contact surface between the guide screw and the lead pipe may be worn or damaged in the course of long-time use. Maintain this portion always smooth.
- 4.Check for oil leak periodically.
- 5.Check the burner tile periodically for breakage.
- 6.For the reducing valve and the oil strainer, refer to the description of “Structure and handling of the accessories” above.

※ Warning Plate

When the installation construction has been completed, check to confirm that the warning plate shown below is firmly attached to the burner body. If the warning plate is lost, immediately contact our sales department for instructions.

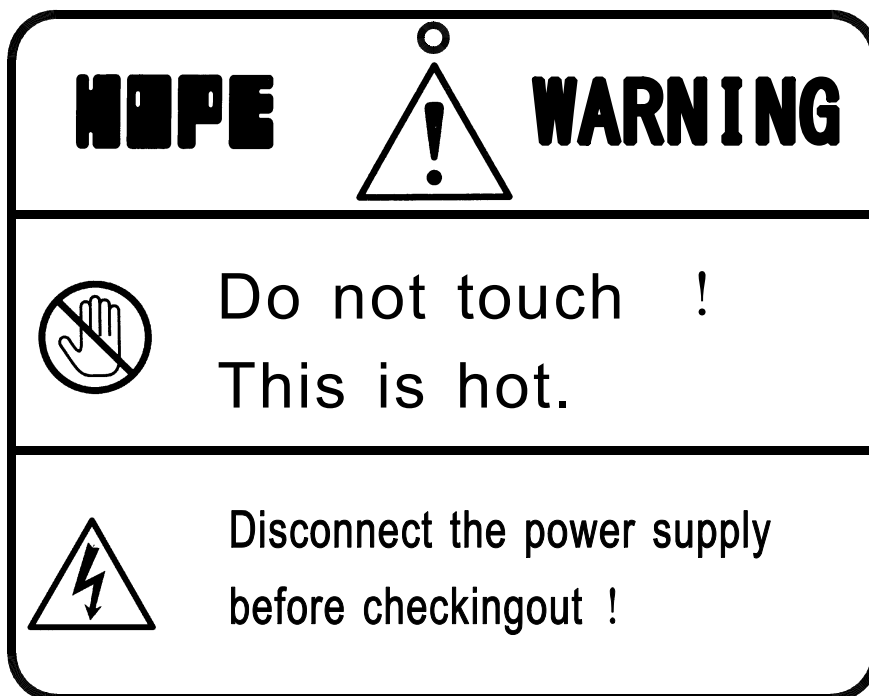

■ Troubleshooting

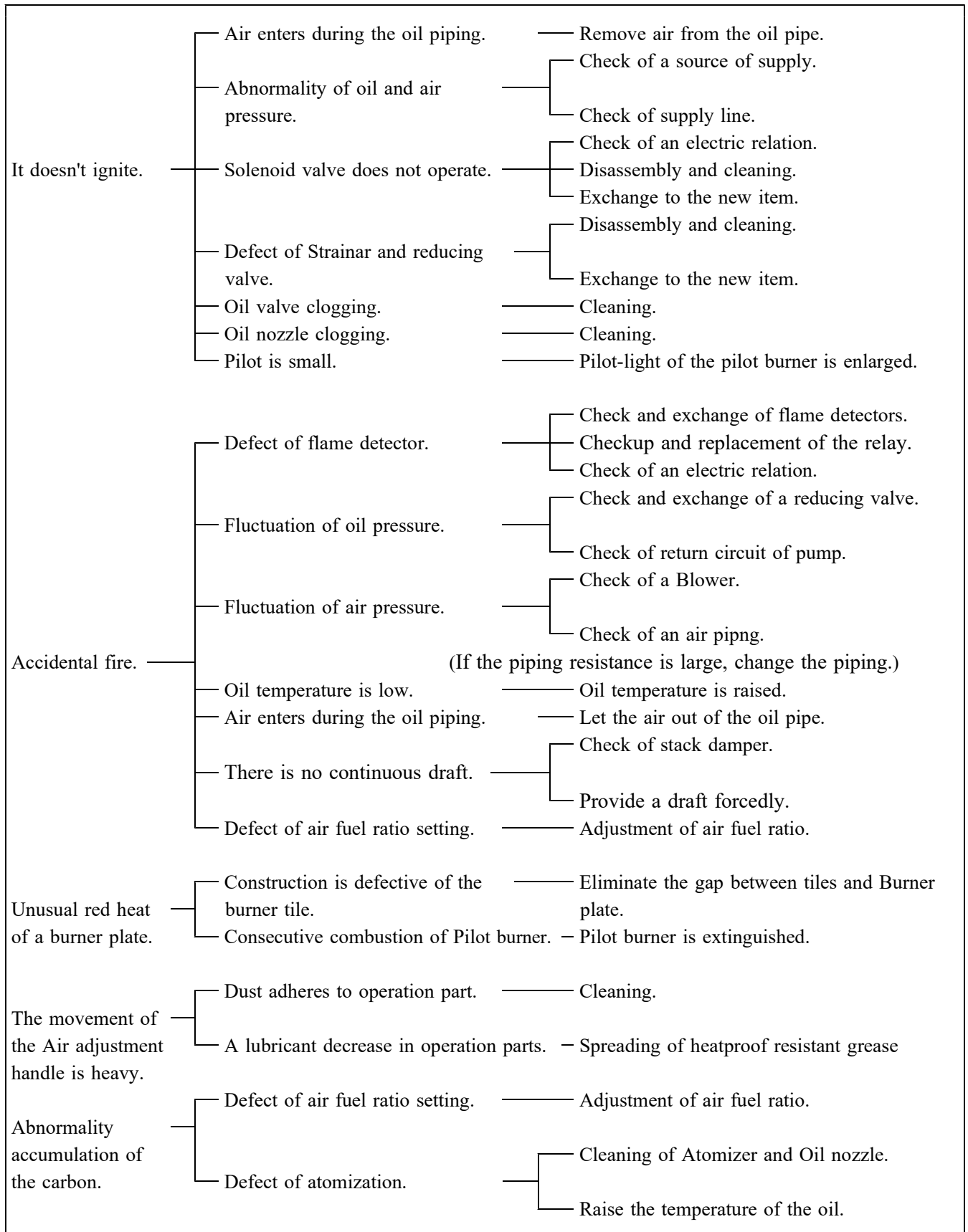

■ Structural Drawing

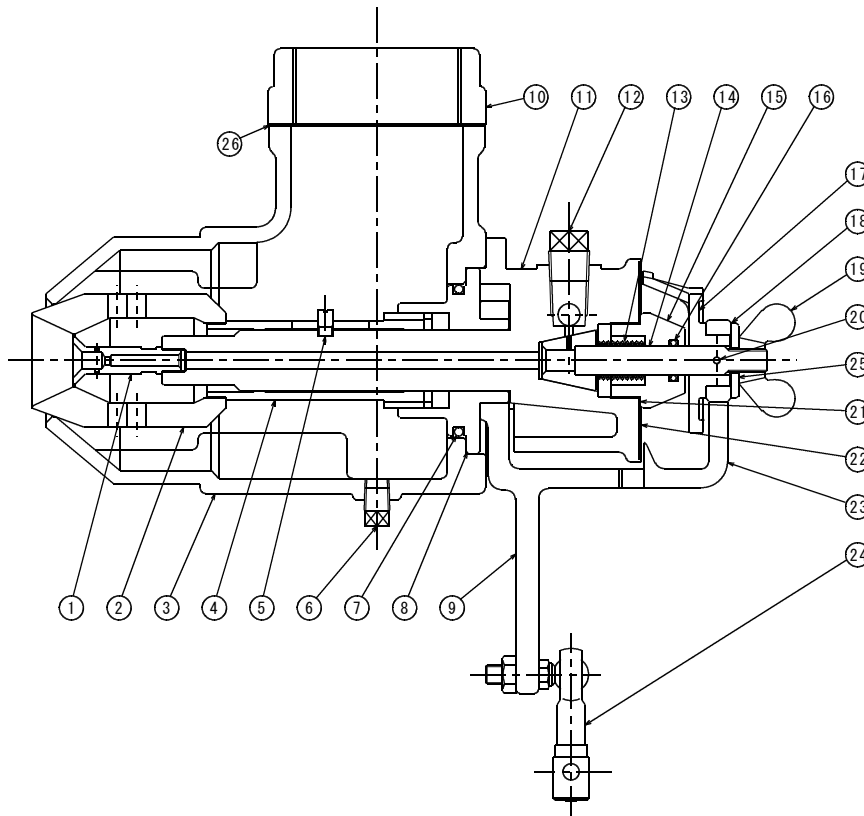

NO.	Parts Name	Quan.	NO.	Parts Name	Quan.
1	Oil Nozzle	1	14	Oil Control Spindle	1
2	Atomizer	1	15	Seal Holder	1
3	Burner Body	1	16	"O"Ring	1
4	Lead Pipe	1	17	Oil Control Handle	1
5	Guide Screw	1	18	Fixed Washer	1
6	Plug	1	19	Fixed Butterfly Nut	1
7	"O"Ring	1	20	Taper Pin	1
8	Operating Bush	1	21	Seal Packing	1
9	Air Control Handle	1	22	Oil Flow Scale	1
10	Flange	1	23	Proportioning Interlock	1
11	Oil Valve Body	1	24	Control Joint	1
12	Plug	1	25	Inner-bladed Washer	1
13	Spindle Holder Spring	1	26	Packing	1

■ Structure

When the air control handle ⑨ is moved, the operating bush ⑧ turns in interlock with it. This turn is conveyed to the atomizer ② installed on the lead pipe ④. The lead pipe ④ is connected to the operating bush ⑧ with a multiple thread screw. The screw lead ④ moves forward/backward along the guide screw ⑤ to vary the air delivery area and the air quantity. On the other hand, when oil control handle ⑰ is turned, the oil control spindle ⑭ connected with the taper pin ⑳ turns. When the delivery area of the taper lead groove provided on the oil control spindle ⑭ varies, the oil quantity also varies. When the proportioning interlock ㉓ is fastened with the fixed butterfly nut ⑲, the air control handle ⑨ and the oil control handle ⑰ interlock with each other, so that the proportional adjustment of the air quantity and oil quantity can be made simultaneously. The ratio of the air quantity to oil quantity can be selected freely by changing the connection position or oil pressure settings.

■ Technical Data

1. Oil flow rate characteristic

Fig. 10 shows the oil flow characteristic of YLP-H type with oil pressure 50kPa, dynamic viscosity 20cSt and specific gravity 0.88. (YLP-L type is as shown in Fig. 10 at normal temperature.)

Fig. 10 Oil flow quantity characteristic diagram

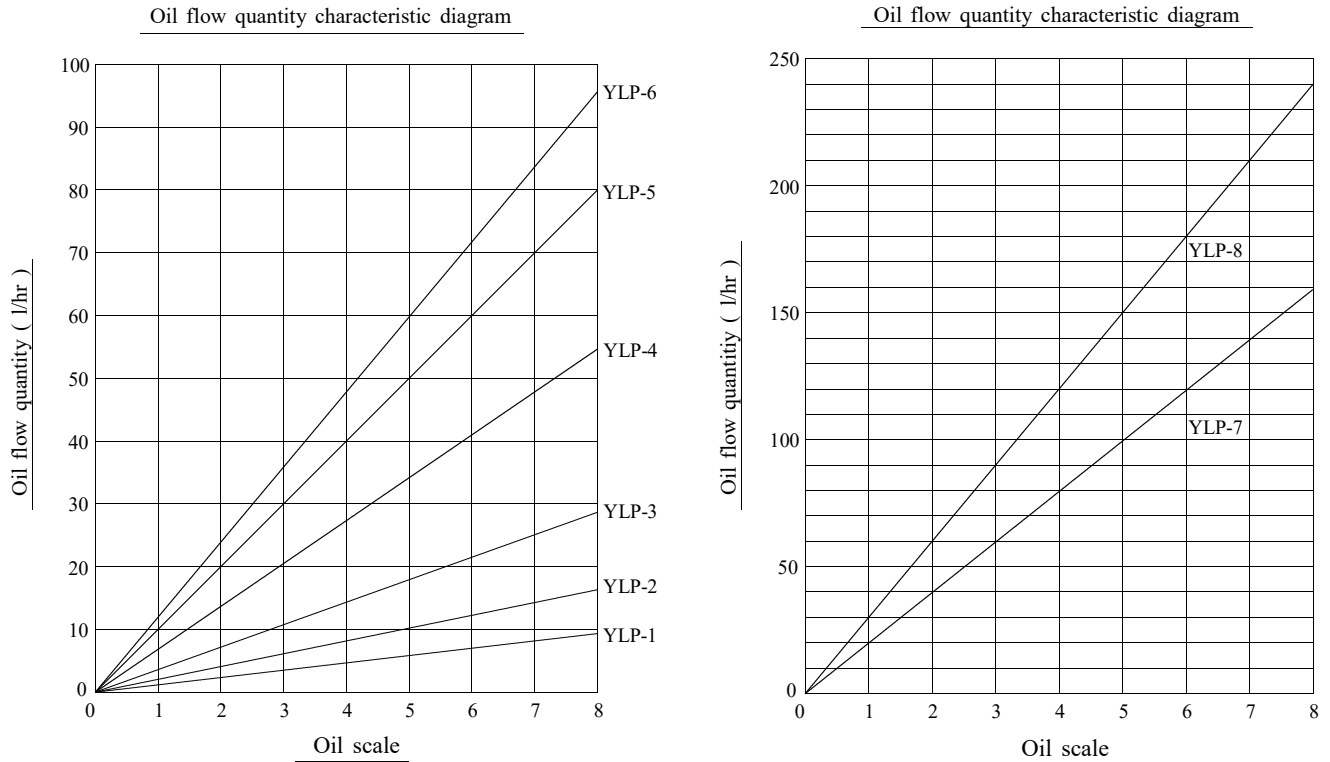

Tables 3, 4 and 5 show the coefficients for various dynamic viscosities and specific gravities

When the values of Fig. 10 are multiplied by the coefficients of Table 3, 4 and 5, the true flow rates can be obtained.

$$\text{Flow rate} = \text{Numeric value of Fig. 10} \times C_1 \cdot C_2 \cdot C_3$$

$$\text{Flow rate precision} = \pm 5\%$$

Table. 3

Oil pressure kPa	20	30	40	50	60	70	80	90	100
Coefficient C_1	0.56	0.75	0.88	1	1.11	1.19	1.28	1.38	1.44

(Note) For YLP-6 type, the coefficient at 70kPa is "1."

Table. 4

Kinematic viscosity cst	5	10	15	20	25	30	50	75	100
Coefficient C_2	1.43	1.19	1.09	1	0.96	0.91	0.81	0.72	0.68

Table. 5

Specific gravity	0.75	0.80	0.83	0.85	0.88	0.90	0.93	0.95	0.98
Coefficient C_3	1.07	1.05	1.03	1.01	1	0.98	0.97	0.96	0.94

2. Air flow rate characteristic

Fig. 11 shows the air flow characteristic at air temperature 20 °C and air pressure 6kPa.

Fig. 11 Air flow quantity characteristic diagram

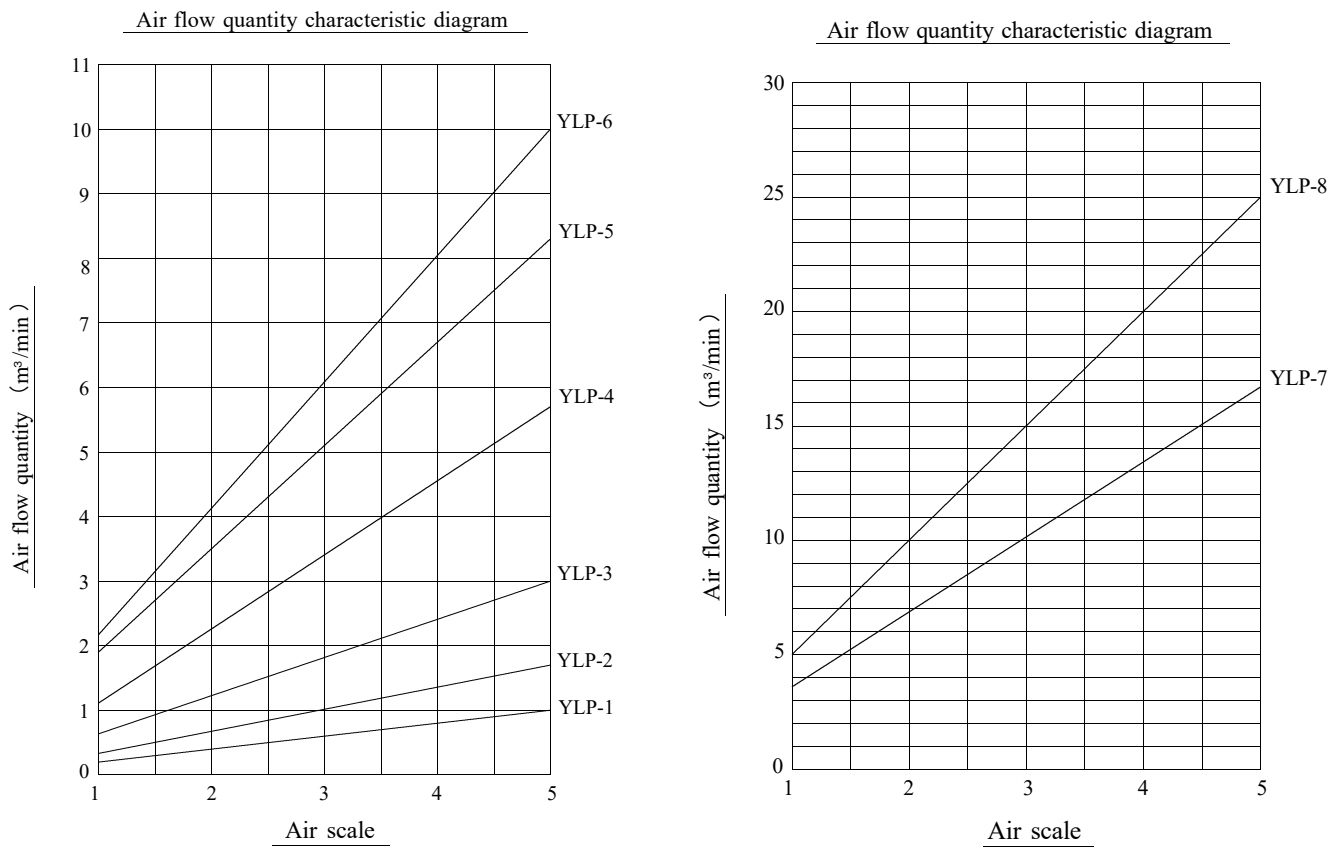

Tables 6 and 7 show the coefficients for various air temperatures and air pressures.

When the values of Fig. 11 are multiplied by the coefficients of table 6 and 7, the true flow rates can be obtained.

$$\text{Flow rate} = \text{Numeric value of Fig. 11} \times C_4 \cdot C_5$$

$$\text{Flow rate precision} = \pm 5\%$$

Table. 6

Temperature °C	10	20	30	40	50	60
Coefficient C ₄	1.02	1	0.98	0.97	0.96	0.94

Table. 7

Air pressure kPa	4	5	6	7	8	9
Coefficient C ₅	0.82	0.91	1	1.08	1.15	1.22

3. Air Piping

The important role of the air piping is to minimize pressure loss. If pressure loss is large, it is difficult to maintain the inner pressure of the burner to a constant level. Therefore, control the total pressure loss to 0.7 to 0.8kPa. The total pressure loss is equal to the sum of the loss due to pipe friction and the loss due to pipe configuration.

Fig. 12 shows the pressure loss due to pipe friction (pressure loss per 100m).

Fig. 12

