

排熱を燃焼用空気の予熱として利用する熱交換器が内蔵された熱交付バーナーです。独自の熱交方法により、高い省エネルギー効果が得られます。ダイレクト点火方式を採用し、ターンダウンは1:5までとれ、100%着火のON-OFF仕様も可能です。また間接加熱用、直接加熱用として使用可能です。

This burner has a built-in heat exchanger to utilize exhaust heat for preheating combustion air. Owing to its unique heat exchanging method, this burner has realized a high energy-saving effect. Also, owing to its direct ignition method, this burner has realized the turn-down ratio up to 1:5. Furthermore, this burner is free from ignition failure in the ON-OFF operation. This burner can also be used for indirect heating and direct heating.

- 燃料 Fuel : 各種燃料ガス Fuel Gases
- 基準圧 Standard Pressure : Gas 10kPa・Air 6kPa
- 炎監視方式 Flame Safeguard System : 紫外線光電管方式 UV Phototube

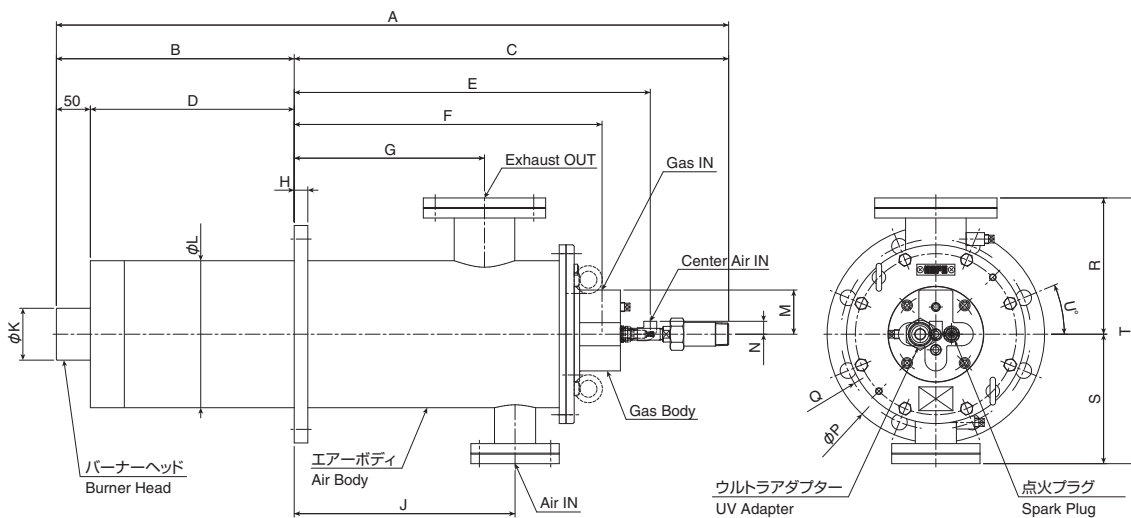
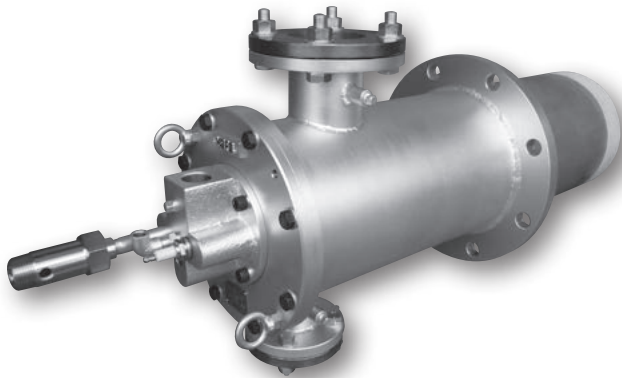

寸法 / DIMENSION

型式 Type	燃焼容量 Cap. kW (x10 <sup>3</sup> kcal/h)	空気流量 Air Flow Rate (m <sup>3</sup> /h (nor.))	接続口径 Connection				A	B	C	D	E	F	G	H	J	K	L	M	N	P	Q	R	S	T	U	質量 Mass (kg)
			Main Air (JIS5KF)	Main Gas (Rc)	Center Air (Rc)	Exh. (JIS5KF)																				
REC-10	100 (86)	114	50 A	1	1/4	80 A	989	350	639	300	524	453	280	19	325	80	217	65	19	320	8-φ23-PCD280	200	190	390	22.5"	85
REC-20	200 (172)	228	65 A	1	3/8	100 A	989	350	639	300	530	453	260	20	320	116	320	65	23	430	12-φ23-PCD390	247	245	492	15"	120

フローシート / FLOW SHEET

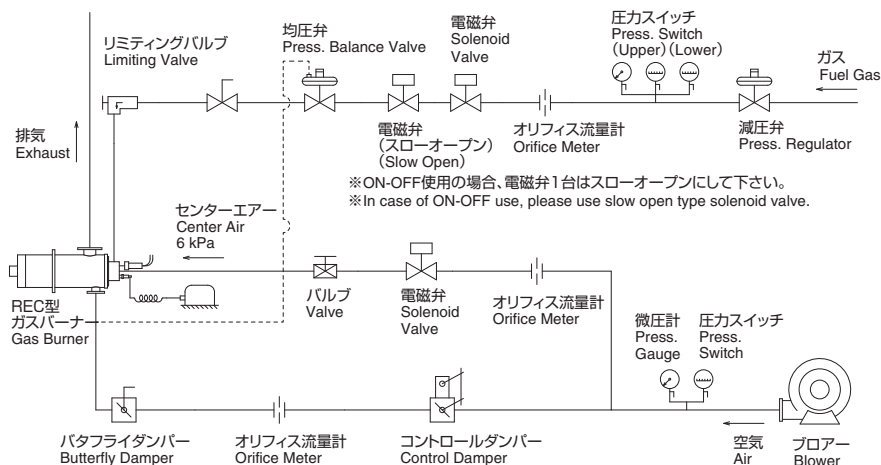

■ ご注文の際は、弊社営業部までご連絡ください。 ■ If you order, please contact our sales department for instructions.

技術資料 / TECHNICAL DATA

バーナー：REC-10  
 燃焼容量：100kW(86×10<sup>3</sup>kcal/h)  
 燃料：13A

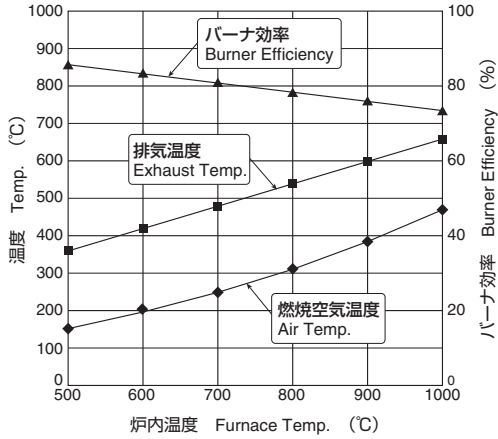

バーナー：REC-10  
 燃焼容量：100kW(86×10<sup>3</sup>kcal/h)  
 燃料：13A

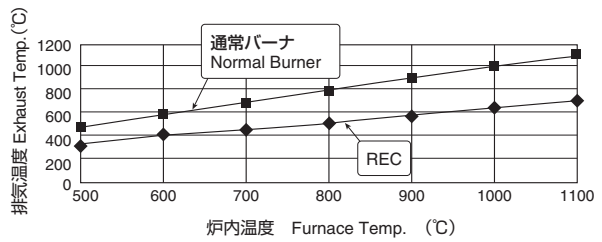
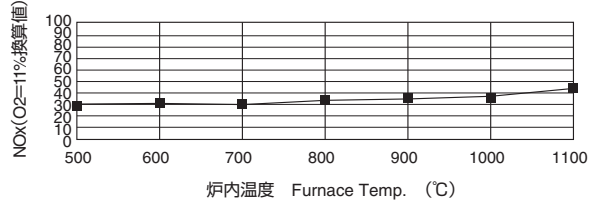

フレイムパターン / FLAME PATTERN

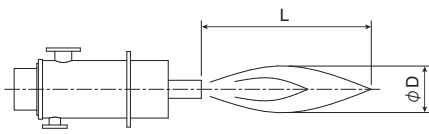

● 運転条件 Condition / 大気中 In The Air

燃焼空気圧力 Air Pressure	6kPa
燃料 Fuel	LPG
空気比 Excess Air Ratio	1.1

Type	φ D	L
REC-10	150	800
REC-20	200	1100

熱交換システム概要 / OUTLINE OF HEAT EXCHANGING SYSTEM

