

**PBC\***  
**PBC-V**

パイロットバーナー (検出型)  
Pilot Burner (Detection Type)

セラミックライニング型  
Ceramic Lining Type

**PBC型**

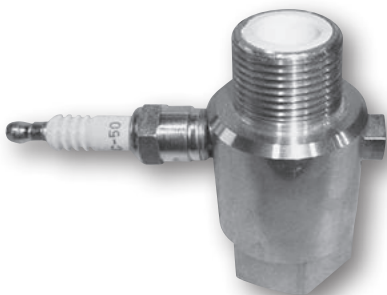

- 基準混合気圧 Standard Mixed Pressure : 1kPa
- 標準付属品 Accessories : 点火プラグ Spark Plug

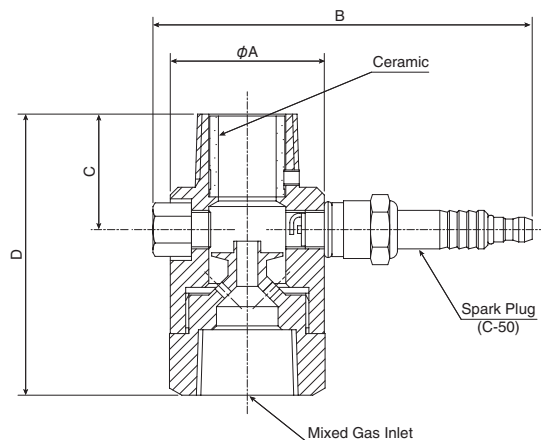

**PBC-V型**

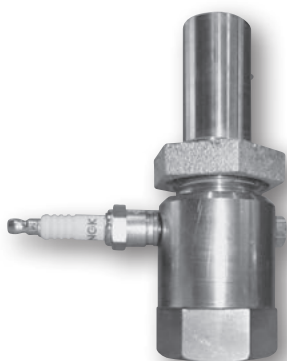

寸法 / DIMENSION

型式 Type	燃焼容量 Cap. kW (×10 <sup>3</sup> kcal/h) at Mixer Gas 1.0kPa	接続口径 Connection		A	B	C	D	質量 Mass (kg)
		Mixed Gas (Rc)	Out (R)					
PBC-2	3.4 ( 2.9)	3/4	3/4	40	98	30	73	0.4
PBC-3	6.5 ( 5.6)	1	1	46	103	33	82	0.6
PBC-4	17.4 (15.0)	1	1 1/2	58	115	39	103	1.2

**PB\***

パイロットバーナー  
Pilot Burner

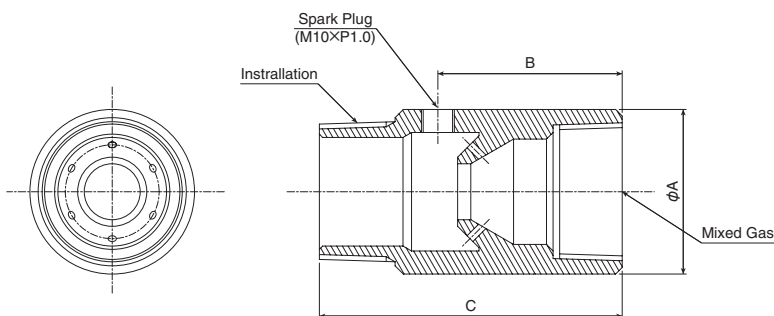

寸法 / DIMENSION

型式 Type	燃焼容量 Cap. kW (×10 <sup>3</sup> kcal/h) at Mixer Gas 1.0kPa	接続口径 Connection		A	B	C	バーナーノズル面積 Burner Nozzle Size (mm <sup>2</sup> )	質量 Mass (kg)
		Mixed Gas (Rc)	Out (R)					
PB-1	5.8 ( 5)	1/2	1/2	26	40	67	48.5	0.1
PB-2	11.6 (10)	3/4	3/4	32	43	73	97.4	0.2
PB-3	24.4 (21)	1	1	40	49	82	178.9	0.4
PB-4	32.6 (28)	1 1/4	1 1/4	50	56	92	256.4	0.6
PB-5	48.8 (42)	1 1/2	1 1/2	57	63	103	348.5	0.9