

シンプルなクランプ機構によりバーナーノズル部、バーナータイルの保守点検が容易に行うことができます。

The simple clamp mechanism makes maintenance of the burner nozzle or burner tile easy.

- 燃 料 Fuel : 各種燃料ガス Fuel Gases
- 基 準 圧 Standard Pressure : Gas 2 ~ 10kPa ・ Air 6kPa

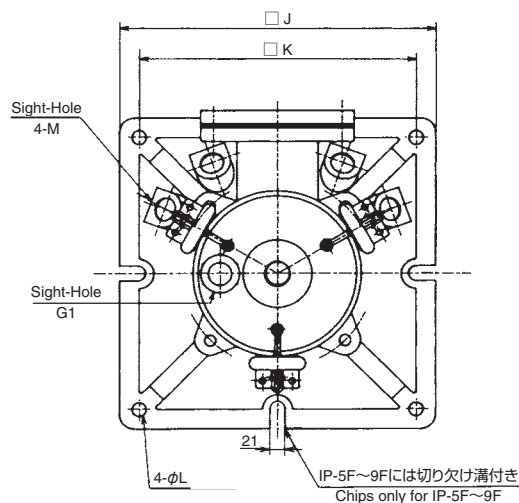
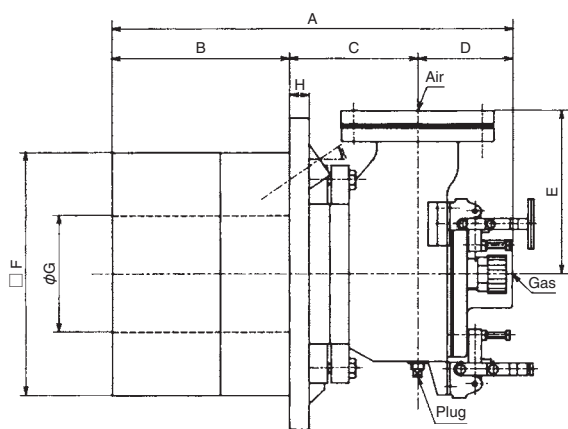
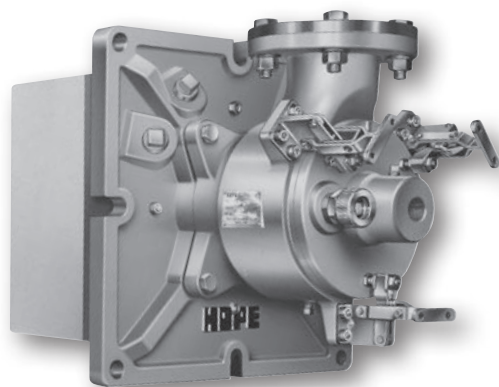

寸法 / DIMENSION

型式 Type	燃焼容量 Cap. kW (x10 ³ kcal/h)	空気流量 Air Flow Rate (m ³ /h (nor.))	接続口径 Connection		A	B	C	D	E	F	G	H	J	K	L	M (G)	質量 Mass (kg)
			Air (JIS5K)	Gas (Rc)													
IP-1FA	58 (50)	60	40 A	3/4	386	160	130	96	157	180	100	20	240	210	15	3/4	30
IP-2FA	116 (100)	120															
IP-3FA	174 (150)	180	65 A	1	407	180	170	96	199	230	120	24	320	280	21	1	49
IP-4FA	233 (200)	240															
IP-5FA	290 (250)	300	80 A	1	476	210	170	96	199	300	150	24	390	350	21	1	77
IP-6FA	350 (300)	360															
IP-7FA	465 (400)	480	100 A	1 1/2	506	180	106	221	320	170	170	24	410	370	21	1	90
IP-8FA	580 (500)	600															
IP-9FA	700 (600)	720															

※角型タイル発注の場合は、型式の後に A を付けて下さい。
※ IP のエア接続はフランジ式です。(JIS5K)

※ In placing an order for square tiles, affix "A" to the end of the model No. (例 Ex.IP-1FA)
※ IP are flanged for connection to the air.

フレームパターン / FLAME PATTERN

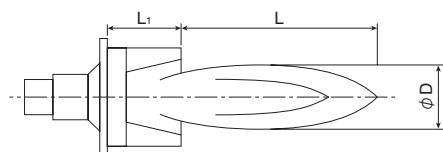

● 運転条件 Condition / 大気中 In The Air	
燃焼空気圧力 Air Pressure	6kPa
燃 料 Fuel	LPG
空気比 Excess Air Ratio	1.1

Type	φ D	L	L ₁
IP-1FA	160	800	160
IP-2FA	200	900	160
IP-3FA	250	1100	180
IP-4FA	250	1200	180
IP-5FA	300	1300	210
IP-6FA	350	1300	210
IP-7FA	350	1400	210
IP-8FA	400	1700	210
IP-9FA	400	1900	210

シンプルなクランプ機構によりバーナーノズル部、バーナータイルの保守点検が容易に行うことができます。

The simple clamp mechanism makes maintenance of the burner nozzle or burner tile easy.

- 燃 料 Fuel : 各種燃料ガス Fuel Gases
- 基 準 圧 Standard Pressure : Gas 2 ~ 10kPa · Air 6kPa

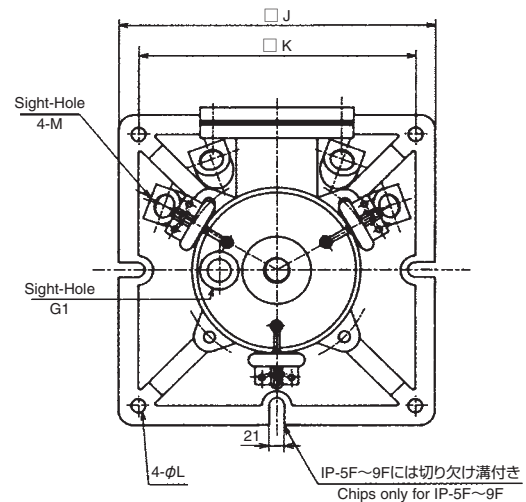
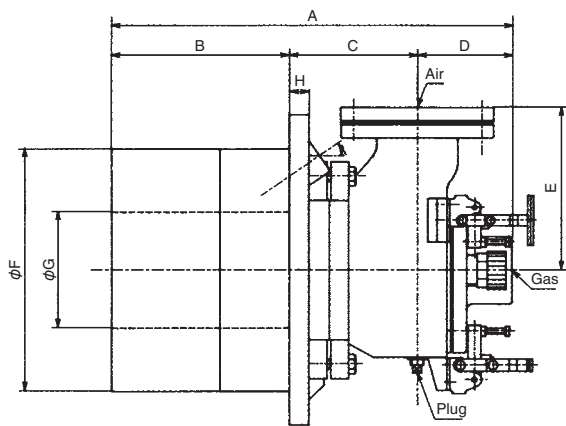
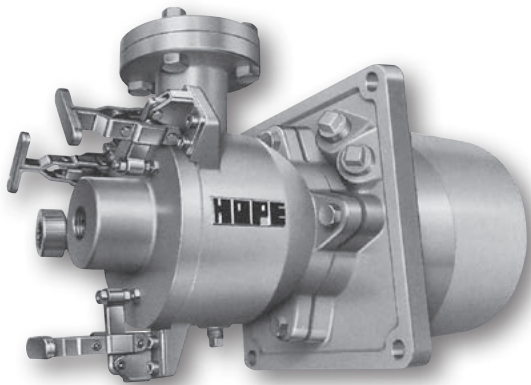

寸 法 / DIMENSION

型式 Type	燃焼容量 Cap. kW (×10 ³ kcal/h)	空気流量 Air Flow Rate (m ³ /h (nor.))	接続口径 Connection		A	B	C	D	E	F	G	H	J	K	L	M (G)	質量 Mass (kg)									
			Air (JIS5K)	Gas (Rc)																						
IP-1FR	58 (50)	60	40 A	3/4	386	160	130	96	157	200	100	20	240	210	15	3/4	30									
IP-2FR	116 (100)	120	65 A		407	180		97	169	250	120		320	280												
IP-3FR	174 (150)	180			80 A	476		210	170	96	199		320	150				24	390	350	21	73				
IP-4FR	233 (200)	240	100 A	506			180					106			221	340	170						410	370	1	86
IP-5FR	290 (250)	300			1 1/2	506		180	106	221	340		170	410				370	1	86						
IP-6FR	350 (300)	360	80 A	476			210					170			96	199	320				150	24	390	350	21	73
IP-7FR	465 (400)	480																								
IP-8FR	580 (500)	600	100 A	506			180					106			221	340	170				410	370	1	86		
IP-9FR	700 (600)	720			100 A	506		180	106	221	340		170	410				370	1	86						

※丸型タイル発注の場合は、型式の後に R を付けて下さい。

※ In placing an order for round tiles, affix "R" to the end of the model No. (例 Ex.IP-1FR)

※ IP のエア接続はフランジ式です。(JIS5K)

※ IP are flanged for connection to the air.

フレイムパターン / FLAME PATTERN

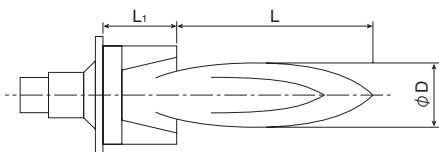

● 運転条件 Condition / 大気中 In The Air

燃焼空気圧力 Air Pressure	6kPa
燃 料 Fuel	LPG
空気比 Excess Air Ratio	1.1

Type	ϕD	L	L ₁
IP-1FR	160	800	160
IP-2FR	200	900	160
IP-3FR	250	1100	180
IP-4FR	250	1200	180
IP-5FR	300	1300	210
IP-6FR	350	1300	210
IP-7FR	350	1400	210
IP-8FR	400	1700	210
IP-9FR	400	1900	210